

NO.	QTY	DESCRIPTION	MODEL NUMBER				STANDARD SEAL KIT	FKM SEAL KIT
			42-1120-02-US	42-1120-03-US	42-1120-08-US	42-1120-04-US		
1	1	SENSOR, ULTRASONIC, M12, 1m	29740200	29740200	29740200	29740200		
2	1	O-RING, (-029)	39001013	39001013	39001013	39001013	X	39012014
3	1	WIPER, SNAP-IN, (1-1/8)	39050020	39050020	39050020	39050020	X	X
4	1	SEAL, LL, (1-1/8 X 1/8 X 1-3/8)	39011048	39011048	39011048	39011048	X	39012007
5	2	O-RING, (-011)	39050042	39050042	39050042	39050042	X	39051025
6	1	PISTON, CYL, 8800, US	82011014	82011011	82011012	82011013		
7	1	GLAND, CYL, 8800 & 39.9 kN	82031002	82031002	82031002	82031002		
8	1	SEAL, T, (1-5/16 X 5/32 X 1-1/2)	39H10017	39H10017	39H10017	39H10017	X	39V11031
9	1	SENSOR, FACE SEAL	43000040	43000040	43000040	43000040		
	1	SENSOR, FACE SEAL, FKM	43000041	43000041	43000041	43000041		
N/A	N/A	SEAL KIT, STANDARD	60210200	60210200	60210200	60210200	N	
N/A	N/A	SEAL KIT, FKM	6V210210	6V210210	6V210210	6V210210		N

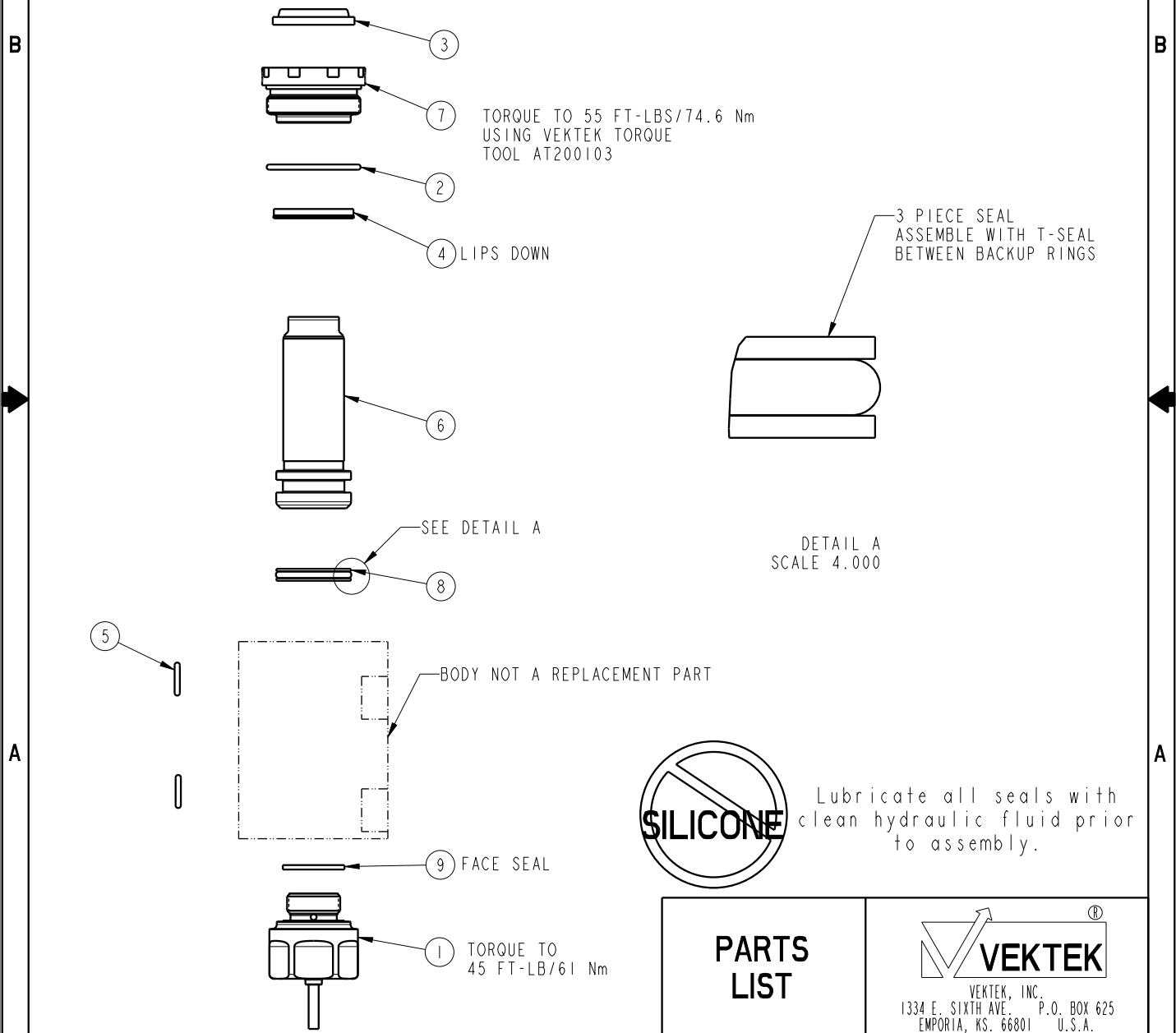

A	5660	RELEASE	ALS	3/24/25
REV	IN ACCORDANCE WITH ECN	EFFECTIVE DATE	REVISED BY	DATE
DRW BY:	ALS	DRAWING STATUS: Released		
DATE:	3/21/25	PRODUCTION APPROVED FOR RELEASED STATUS ONLY		

PARTS LIST	 VEKTEK, INC. 1334 E. SIXTH AVE. P.O. BOX 625 EMPORIA, KS. 66801 U.S.A.
SIZE A	MPLV2101
REV A	